

GU Safety

cmatic[®]
PNEUMATIC FITTINGS

安全快速接头
Safety Couplings



GU 41

安全型按钮式快速接头，ISO 6150 C-10外形

Push-Button Safety Coupling according to ISO 6150 C-10

1	2	3	4	5	6	
本体 Body	阀芯 Valve	螺纹 Thread	按钮 Button	密封圈 Seals	弹簧 Springs	接头 Plugs
阳极氧化铝 Anodised Aluminium	黄铜UNI EN 12164 CW614N Brass UNI EN 12164 CW614N	UNI EN 12164 CW614N镀镍黄铜 Brass nickel plated UNI EN 12164 CW614N	硬化镀锌钢 Hardened, zinc plated steel	NBR NBR	AISI 302不锈钢 Stainless Steel AISI 302	硬化镀锌钢 Hardened, zinc plated steel

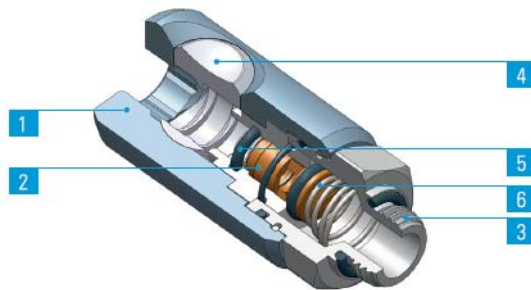
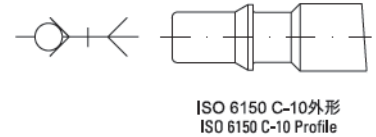

快速接头在安装后依然可以调整方向。
The coupling will remain swivelling after installation.

连接 - 断开

只需将接头插入本体即可。

如需将接头与内螺纹本体断开，必须执行以下2个简单步骤：

将接头插入内螺纹本体

阶段1：

按下松开按钮，从下游回路排出空气；此阶段内接头的内螺纹内部依然锁定。

阶段2：

再次按下按钮，从内螺纹本体内取出接头。

CONNECTION - TO RELEASE

Insert the plug into the Coupling

To disconnect the plug follow instructions below:

Plug inserted in Coupling

Step 1:

Press the button once to vent the downstream air from the circuit; at this time the plug is still captive in the coupling.

Step 2:

Press the button one more time to release the plug.

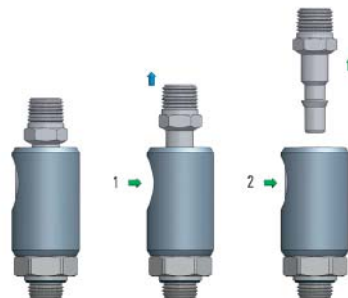

GU 41-10

外螺纹接头体

Male Coupling

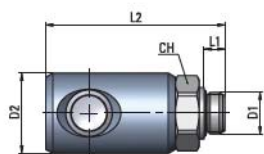

类型	D1	D2	L1	L2	CH	g ΔΔ
10 00 14	G1/4	25	6,5	56	21	89,75
10 00 38	G3/8	25	7	56	21	91,02
10 00 12	G1/2	25	8,5	58,5	25	112,94

GU 41-12

内螺纹接头体

Female Coupling

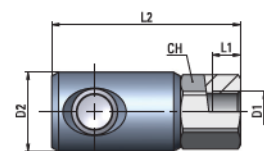

类型	D1	D2	L1	L2	CH	g ΔΔ
12 00 14	G1/4	25	9	59,5	21	111,02
12 00 38	G3/8	25	10	61,5	21	107,71
12 00 12	G1/2	25	11	63,5	24	120

GU 41-13

软管用接头体

Coupling with Hose Connection

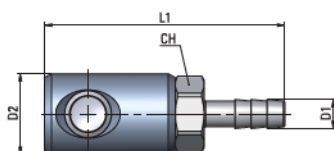

类型	管径Øi	D1	D2	L2	CH	g ΔΔ
13 06 00	6	7	25	74,5	21	93,12
13 08 00	8	9	25	74,5	21	94,48
13 10 00	10	11	25	74,5	21	95,69

GU 41-20

外螺纹插头体

Male Plug

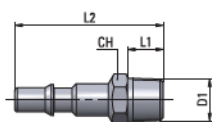

类型	D1	L1	L2	CH	g ΔΔ
20 00 14	R1/4	11	46	14	18
20 00 38	R3/8	11,5	46,5	17	23,5
20 00 12	R1/2	14	49	22	36,5

GU 41-21

内螺纹插头体

Female Plug

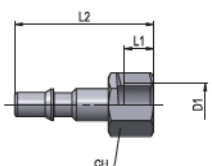

类型	D1	L1	L2	CH	g ΔΔ
21 00 14	G1/4	10	43	17	23
21 00 38	G3/8	10	45	20	29
21 00 12	G1/2	11	47	24	41

GU 41-22

软管用插头体

Plug with Hose Connection

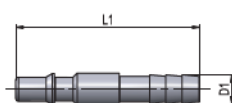

类型	管径Øi	D1	L1	g ΔΔ
22 06 00	6	7	57	12,3
22 08 00	8	9	57	14,7
22 10 00	10	11	57	21,2

GU 42

安全型按钮式快速接头，ISO 6150 B-12外形

Push-Button Safety Coupling according to ISO 6150 B-12

1	2	3	4	5	6	
本体 Body	按钮、阀芯和排气孔 Button, Valve and Venting Ring	螺纹 Thread	弹簧 Springs	滚珠 Balls	密封圈 Seals	接头 Plugs
阳极氧化铝 Anodised Aluminium	硬化镀锌钢 Hardened, zinc plated steel	UNI EN 12164 CW614N镀镍 黄铜 Brass nickel plated UNI EN 12164 CW614N	AISI 302不锈钢 Stainless Steel AISI 302	AISI 420不锈钢 Stainless Steel AISI 420	NBR NBR	硬化镀锌钢 Hardened, zinc plated steel

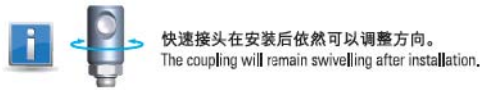
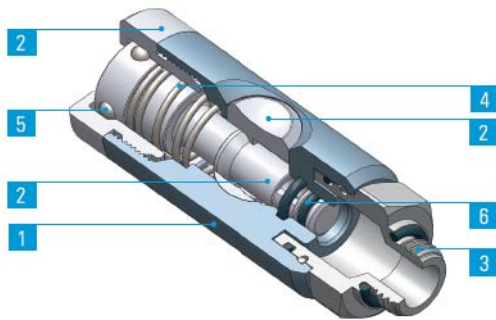
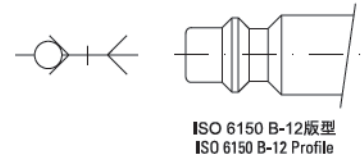

连接 - 断开 CONNECTION - TO RELEASE

只需将接头插入本体即可。

Insert the plug into the Coupling

如需将接头与内螺纹本体断开，必须执行以下2个简单步骤：

To disconnect the plug follow instructions below:

将接头插入内螺纹本体

Plug inserted in Coupling

阶段1：

Step 1:

按下松开按钮，从下游回路排出空气；此阶段内接头的内螺纹内部依然锁定。

Press the button once to vent the downstream air from the circuit; at this time the plug is still captive in the coupling.

阶段2：

Step 2:

再次按下按钮，从内螺纹本体内取出接头。

Press the button one more time to release the plug.

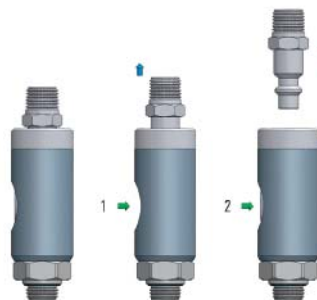

GU 42-10

外螺纹接头体

Male Coupling

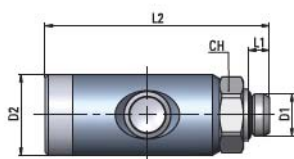

类型	D1	D2	L1	L2	CH	g ΔΔ
10 00 14	G1/4	25	6,5	69,5	21	116,95
10 00 38	G3/8	25	7	69,5	21	118,28
10 00 12	G1/2	25	8,5	72	25	140,38

GU 42-12

内螺纹接头体

Female Coupling

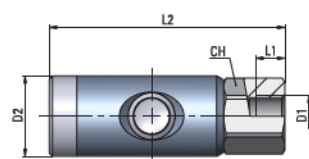

类型	D1	D2	L1	L2	CH	g ΔΔ
12 00 14	G1/4	25	9	73	21	138,22
12 00 38	G3/8	25	10	75	21	134,91
12 00 12	G1/2	25	11	77	24	147,19

GU 42-13

软管用接头体

Coupling with Hose Connection

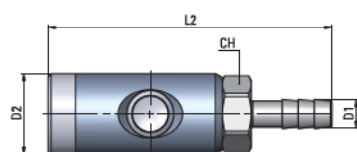

类型	管径 Øi	D1	D2	L2	CH	g ΔΔ
13 06 00	6	7	25	88	21	120,32
13 08 00	8	9	25	88	21	121,88
13 10 00	10	11	25	88	21	122,88

GU 42-20

外螺纹插头体

Male Plug

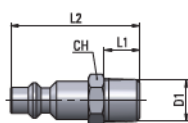

类型	D1	L1	L2	CH	g ΔΔ
20 00 14	R1/4	11	40	14	20
20 00 38	R3/8	11,5	41,5	17	26
20 00 12	R1/2	14	44	22	40

GU 42-21

内螺纹插头体

Female Plug

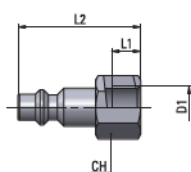

类型	D1	L1	L2	CH	g ΔΔ
21 00 14	G1/4	10	38	17	25
21 00 38	G3/8	11	40	20	31,5
21 00 12	G1/2	11	42	24	43,5

GU 43

安全型按钮式快速接头，ISO 6150 C-14外形

Push-Button Safety Coupling according to ISO 6150 C-14

1	2	3	4	5	6	
本体 Body	阀芯 Valve	螺纹 Thread	按钮 Button	密封圈 Seals	弹簧 Springs	接头 Plugs
阳极氧化铝 Anodised Aluminium	黄铜UNI EN 12164 CW614N Brass UNI EN 12164 CW614N	UNI EN 12164 CW614N镀镍 黄铜 Brass nickel plated UNI EN 12164 CW614N	硬化镀锌钢 Hardened, zinc plated steel	NBR NBR	AISI 302不锈钢 Stainless Steel AISI 302	硬化镀锌钢 Hardened, zinc plated steel

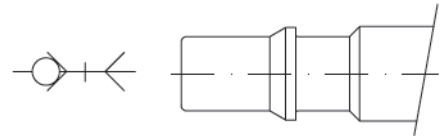

ISO 6150 C-14外形
ISO 6150 C-14 Profile

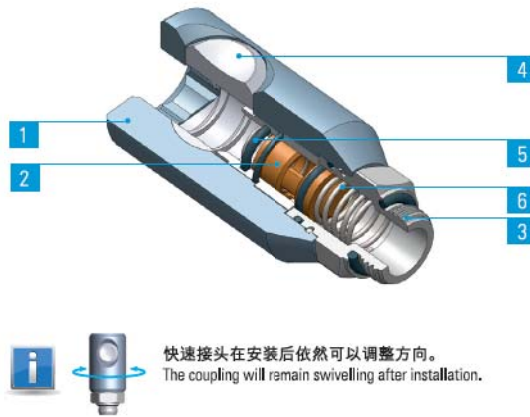

快速接头在安装后依然可以调整方向。
The coupling will remain swivelling after installation.

连接 - 断开

只需将接头插入本体即可。

如需将接头与内螺纹本体断开，必须执行以下2个简单步骤：

将接头插入内螺纹本体

阶段1：

按下松开按钮，从下游回路排出空气；此阶段内接头的内螺纹内部依然锁定。

阶段2：

再次按下按钮，从内螺纹本体内取出接头。

CONNECTION - TO RELEASE

Insert the plug into the Coupling

To disconnect the plug follow instructions below:

Plug inserted in Coupling

Step 1:

Press the button once to vent the downstream air from the circuit; at this time the plug is still captive in the coupling.

Step 2:

Press the button one more time to release the plug.

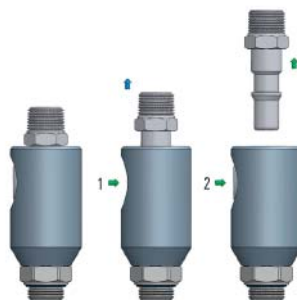

GU 43-10

外螺纹接头体

Male Coupling

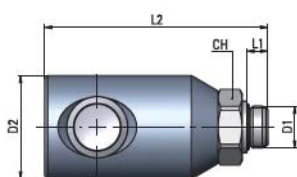

类型	D1	D2	L1	L2	CH	g ΔΔ
10 00 14	G1/4	32	6,5	69	21	149,2
10 00 38	G3/8	32	7	69	21	150,54
10 00 12	G1/2	32	8,5	72	25	172,63

GU 43-12

内螺纹接头体

Female Coupling

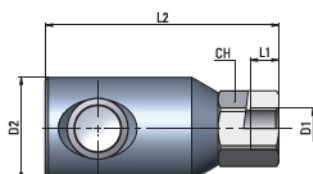

类型	D1	D2	L1	L2	CH	g ΔΔ
12 00 14	G1/4	32	9	73	21	170,47
12 00 38	G3/8	32	10	75	21	167,16
12 00 12	G1/2	32	11	77	24	179,45

GU 43-13

软管用接头体

Coupling with Hose Connection

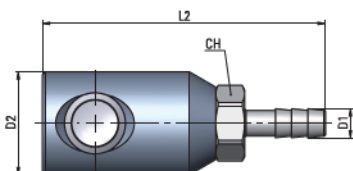

类型	管径Øi	D1	D2	L2	CH	g ΔΔ
13 08 00	8	9	32	88	21	153,93
13 10 00	10	11	32	88	21	155,14
13 13 00	13	14	32	88	21	162,2

GU 43-20

外螺纹插头体

Male Plug

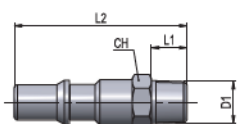

类型	D1	L1	L2	CH	g ΔΔ
20 00 14	R1/4	11	53,5	15	32
20 00 38	R3/8	11,5	54	17	35,5
20 00 12	R1/2	14	56,5	22	51

GU 43-21

内螺纹插头体

Female Plug

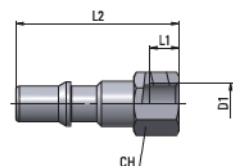

类型	D1	L1	L2	CH	g ΔΔ
21 00 14	G1/4	10	50,5	17	35
21 00 38	G3/8	11	52,5	20	42
21 00 12	G1/2	11	54,5	24	53

GU 43-22

软管用插头体

Plug with Hose Connection

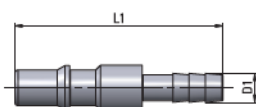

类型	管径Øi	D1	L1	g ΔΔ
22 08 00	8	9	64,5	26,5
22 10 00	10	11	64,5	27
22 13 00	13	14	64,5	39

GU 44

安全型按钮式快速接头，ISO 6150 B-15外形

Push-Button Safety Coupling according to ISO 6150 B-15

1	2	3	4	5	6	
本体 Body	按钮、阀芯和排气孔 Button, Valve and Venting Ring	螺纹 Thread	弹簧 Springs	滚珠 Balls	密封圈 Seals	接头 Plugs
阳极氧化铝 Anodised Aluminium	硬化镀锌钢 Hardened, zinc plated steel	UNI EN 12164 CW614N 镀镍 黄铜 Brass nickel plated UNI EN 12164 CW614N	AISI 302 不锈钢 Stainless Steel AISI 302	AISI 420 不锈钢 Stainless Steel AISI 420	NBR NBR	硬化镀锌钢 Hardened, zinc plated steel

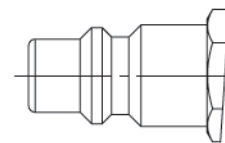
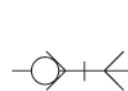
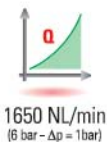

ISO 6150 B-15外形
ISO 6150 B-15 Profile

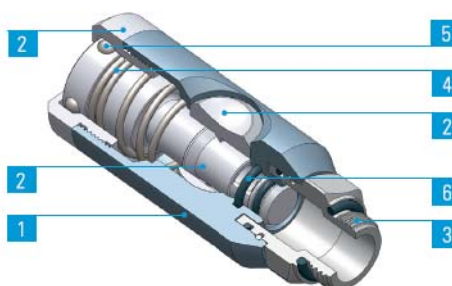

快速接头在安装后依然可以调整方向。
The coupling will remain swivelling after installation.

连接 - 断开

只需将接头插入本体即可。

如需将接头与内螺纹本体断开，必须执行以下2个简单步骤：

将接头插入内螺纹本体

阶段1：

按下松开按钮，从下游回路排出空气；此阶段内接头的内螺纹内部依然稳定。

阶段2：

再次按下按钮，从内螺纹本体内取出接头。

CONNECTION - TO RELEASE

Insert the plug into the Coupling

To disconnect the plug follow instructions below:

Plug inserted in Coupling

Step 1:

Press the button once to vent the downstream air from the circuit; at this time the plug is still captive in the coupling.

Step 2:

Press the button one more time to release the plug.



GU 44-10

外螺纹接头体

Male Coupling

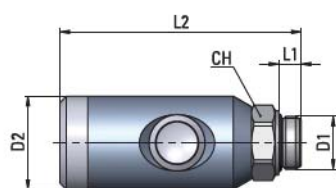

类型	D1	D2	L1	L2	CH	g ΔΔ
10 00 38	G3/8	29	7	75	21	150.78
10 00 12	G1/2	29	8.5	78	25	172.57

GU 44-12

内螺纹接头体

Female Coupling

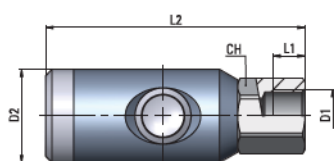

类型	D1	D2	L1	L2	CH	g ΔΔ
12 00 38	G3/8	29	10	81	21	167.1
12 00 12	G1/2	29	11	83	24	179.39

GU 44-13

软管用接头体

Coupling with Hose Connection

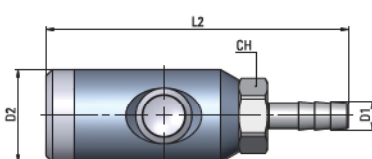

类型	管径 \varnothing_i	D1	D2	L2	CH	g ΔΔ
13 08 00	8	9	29	94	21	1574.38
13 10 00	10	11	29	94	21	155.08
13 13 00	13	14	29	94	21	162.15

GU 44-20

外螺纹插头体

Male Plug

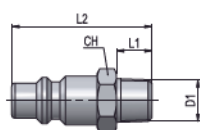

类型	D1	L1	L2	CH	g ΔΔ
20 00 14	R1/4	11	43.5	17	33.65
20 00 38	R3/8	11.5	44	17	34.76
20 00 12	R1/2	14	46.5	22	50.3

GU 44-21

内螺纹接头

Female plug

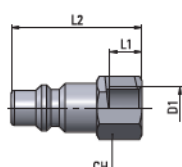

类型	D1	L1	L2	CH	g ΔΔ
21 00 14	G1/4	10	40.5	17	33.72
21 00 38	G3/8	11	42.5		40.6
21 00 12	G1/2	11	44.5	24	52.3

GU 45

安全型按钮式快速接头，ARO 210外形

Push-Button Safety Coupling according to ARO 210

1	2	3	4	5	6	
本体 Body	按钮、阀芯和排气孔 Button, Valve and Venting Ring	螺纹 Thread	弹簧 Springs	滚珠 Balls	密封圈 Seals	接头 Plugs
阳极氧化铝 Anodised Aluminium	硬化镀锌钢 Hardened, zinc plated steel	UNI EN 12164 CW614N 镀镍 黄铜 Brass nickel plated UNI EN 12164 CW614N	AISI 302 不锈钢 Stainless Steel AISI 302	AISI 420 不锈钢 Stainless Steel AISI 420	NBR NBR	镀镍钢 Nickel plated steel

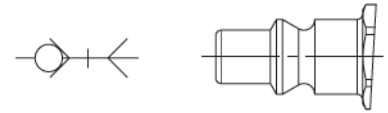

ARO 210外形
ARO 210 Profile

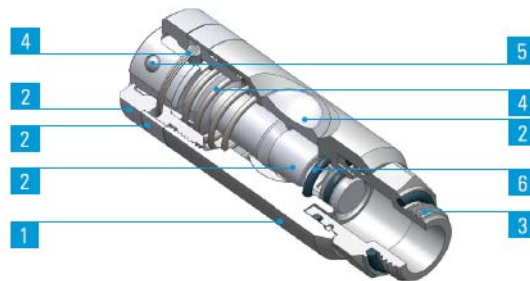

快速接头在安装后依然可以调整方向。
The coupling will remain swivelling after installation.

连接 - 断开

只需将接头插入本体即可。

如需将接头与内螺纹本体断开，必须执行以下2个简单步骤：

将接头插入内螺纹本体

阶段1：

按下松开按钮，从下游回路排出空气；此阶段内接头的内螺纹内部依然锁定。

阶段2：

再次按下按钮，从内螺纹本体内取出接头。

CONNECTION - TO RELEASE

Insert the plug into the Coupling

To disconnect the plug follow instructions below:

Plug inserted in Coupling

Step 1:

Press the button once to vent the downstream air from the circuit; at this time the plug is still captive in the coupling.

Step 2:

Press the button one more time to release the plug.

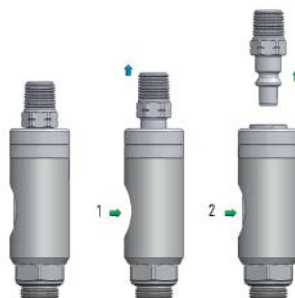

GU 45-10

外螺纹接头体

Male Coupling

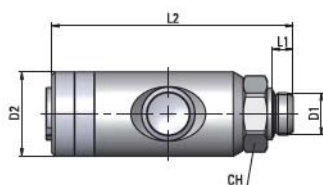

类型	D1	D2	L1	L2	CH	g ΔΔ
10 00 14	G1/4	26	6,5	75	21	144,84
10 00 38	G3/8	26	7	75	21	146,17
10 00 12	G1/2	26	8,5	77,5	25	168,27

GU 45-12

内螺纹接头体

Female Coupling

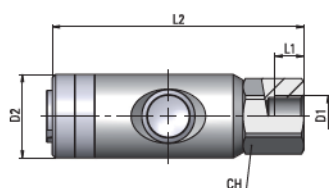

类型	D1	D2	L1	L2	CH	g ΔΔ
12 00 14	G1/4	26	9	78,5	21	166,11
12 00 38	G3/8	26	10	80,5	21	162,8
12 00 12	G1/2	26	11	82,5	24	175,08

GU 45-13

软管用接头体

Coupling with hose connection

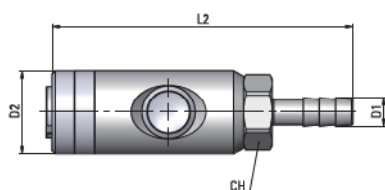

类型	管径 Øi	D1	D2	L2	CH	g ΔΔ
13 06 00	6	7	26	93,5	21	148,21
13 08 00	8	9	26	93,5	21	149,57
13 09 00	9	10	26	93,5	21	150,19
13 10 00	10	11	26	93,5	21	150,77
13 13 00	13	14	26	93,5	21	157,84

GU 45-20

外螺纹插头体

Male Plug

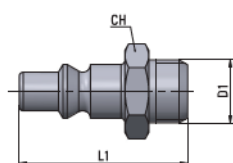

类型	D1	L1	CH	g ΔΔ
20 00 14	G1/4	36	14	17,13
20 00 38	G3/8	40	17	23,51
20 00 12	G1/2	39,5	24	41,25

GU 45-21

内螺纹插头体

Female Plug

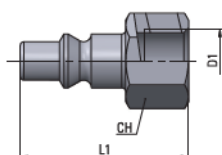

类型	D1	L1	CH	g ΔΔ
21 00 14	G1/4	37	16	18,95
21 00 38	G3/8	40	19	25,34
21 00 12	G1/2	43,5	25	50,39

GU 46

安全型按钮式快速接头，欧洲外形

Push-Button Safety Coupling according to European profile

1	2	3	4	5	6	
本体 Body	按钮、阀芯和排气孔 Button, Valve and Venting Ring	螺纹 Thread	弹簧 Springs	滚珠 Balls	密封圈 Seals	接头 Plugs
阳极氧化铝 Anodised Aluminium	硬化镀锌钢 Hardened, zinc plated steel	UNI EN 12164 CW614N 镀镍 黄铜 Brass nickel plated UNI EN 12164 CW614N	AISI 302 不锈钢 Stainless Steel AISI 302	AISI 420 不锈钢 Stainless Steel AISI 420	NBR NBR	硬化镀锌钢 Hardened, zinc plated steel

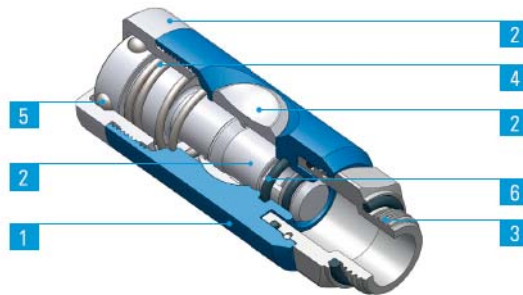
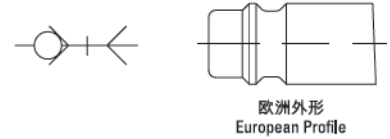

快速接头在安装后依然可以调整方向。
The coupling will remain swivelling after installation.

连接 - 断开

只需将接头插入本体即可。

如需将接头与内螺纹本体断开，必须执行以下2个简单步骤：
将接头插入内螺纹本体

阶段1：

按下松开按钮，从下游回路排出空气；此阶段内接头的内螺纹内部依然锁定。

阶段2：

再次按下按钮，从内螺纹本体内取出接头。

CONNECTION - TO RELEASE

Insert the plug into the Coupling

To disconnect the plug follow instructions below:

Plug inserted in Coupling

Step 1:

Press the button once to vent the downstream air from the circuit; at this time the plug is still captive in the coupling.

Step 2:

Press the button one more time to release the plug.



GU 46-10

外螺纹接头体

Male Coupling

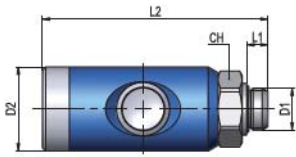

类型	D1	D2	L1	L2	CH	g ΔΔ
10 00 14	G1/4	26	6,5	70	21	123.69
10 00 38	G3/8	26	7	70	21	125.02
10 00 12	G1/2	26	8,5	72,5	25	147.12

GU 46-12

内螺纹接头体

Female Coupling

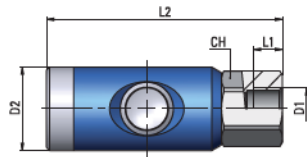

类型	D1	D2	L1	L2	CH	g ΔΔ
12 00 14	G1/4	26	9	73,5	21	144.96
12 00 38	G3/8	26	10	75,5	21	141.65
12 00 12	G1/2	26	11	77,5	24	153.93

GU 46-13

软管用接头体

Coupling with Hose Connection

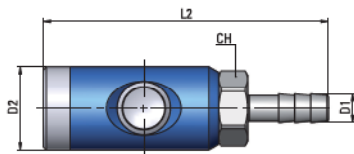

类型	管径Øi	D1	D2	L2	CH	g ΔΔ
13 06 00	6	7	26	88,5	21	127.06
13 08 00	8	9	26	88,5	21	128.42
13 09 00	9	10	26	88,5	21	128.17
13 10 00	10	11	26	88,5	21	129.62
13 13 00	13	14	26	88,5	21	135.82

更多插头体信息，请参看GU26相关部分。

For further info on the plugs to use, please revert to the **GU26 section**.

 **PU Safety**

cmatic[®]
PNEUMATIC FITTINGS

NPT安全快速接头
Safety Couplings, NPT



PU 42

安全型按钮式快速接头，ISO 6150 B-12外形

Push-Button Safety Coupling, according to ISO 6150 B-12

1	2	3	4	5	6	
本体 Body	按钮、阀芯和排气孔 Button, Valve and Venting Ring	螺纹 Thread	弹簧 Springs	滚珠 Balls	密封圈 Seals	接头 Plugs
阳极氧化铝 Anodised Aluminium	硬化镀锌钢 Hardened, zinc plated steel	UNI EN 12164 CW614N 镀镍 黄铜 Brass nickel plated UNI EN 12164 CW614N	AISI 302 不锈钢 Stainless Steel AISI 302	AISI 420 不锈钢 Stainless Steel AISI 420	NBR NBR	硬化镀锌钢 Hardened, zinc plated steel



-20°C - 80°C



0 - 16 bar



5,5 mm



780 NL/min
(6 bar - Δp = 1bar)



ISO 4414



SILICONE FREE



RoHS



REACH

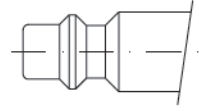
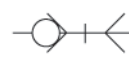

INDUSTRIAL Profile
MIL C4109 Profile
ISO 6150 B-12 Profile

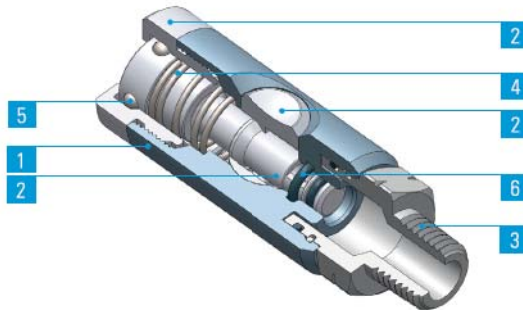

快速接头在安装后依然可以调整方向。
The coupling will remain swivelling after installation.

连接 - 断开

只需将接头插入本体即可。

如需将接头与内螺纹本体断开，必须执行以下2个简单步骤：

将接头插入内螺纹本体

阶段1：

按下松开按钮，从下游回路排出空气；此阶段内接头的内螺纹内部依然锁定。

阶段2：

再次按下按钮，从内螺纹本体内取出接头。

CONNECTION - TO RELEASE

Insert the plug into the Coupling

To disconnect the plug follow instructions below:

Plug inserted in Coupling

Step 1:

Press the button once to vent the downstream air from the circuit; at this time the plug is still captive in the coupling.

Step 2:

Press the button one more time to release the plug.

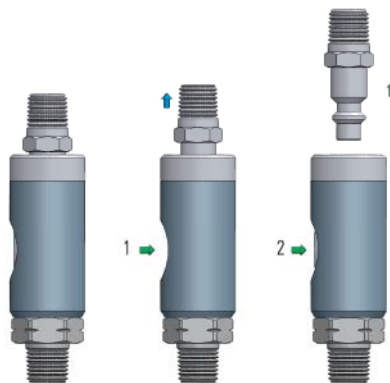

PU 42-11

外螺纹接头体

Male Coupling

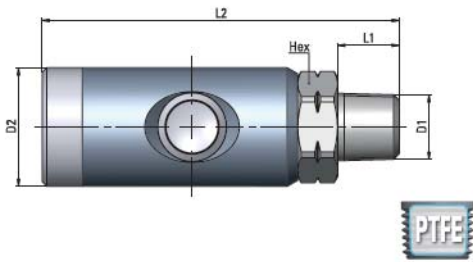

类型	D1 NPTF	D2	L1	L2	HEX (mm)	g ΔΔ
11 00 14	1/4	25	13	75,5	21	110,10
11 00 38	3/8	25	13	74,5	21	120,34
11 00 12	1/2	25	17	78,5	22	-

PU 42-12

内螺纹接头体

Female Coupling

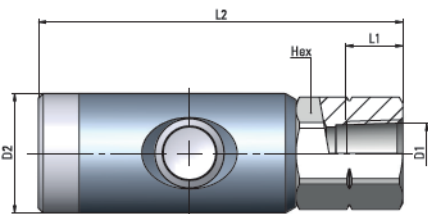

类型	D1 NPTF	D2	L1	L2	HEX (mm)	g ΔΔ
12 00 14	1/4	25	12	76,5	21	127,60
12 00 38	3/8	25	12,5	77	21	118,00
12 00 12	1/2	25	13,5	79	24	140,00

PU 42-20

外螺纹插头体

Male Plug

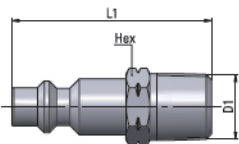

类型	D1 NPTF	L1	HEX (mm)	g ΔΔ
20 00 14	1/4	42	14	22,60
20 00 38	3/8	42	18	28,90
20 00 12	1/2	47	22	43,10

PU 42-21

内螺纹插头体

Female Plug

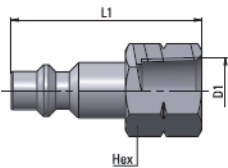

类型	D1 NPTF	L1	HEX (mm)	g ΔΔ
21 00 14	1/4	40	17	28,10
21 00 38	3/8	40	20	31,60
21 00 12	1/2	44	24	50,00

PU 44

安全型按钮式快速接头，ISO 6150 B-15外形

Push-Button Safety Coupling according to ISO 6150 B-15

1	2	3	4	5	6	
本体 Body	按钮、阀芯和排气孔 Button, Valve and Venting Ring	螺纹 Thread	弹簧 Springs	滚珠 Balls	密封圈 Seals	接头 Plugs
阳极氧化铝 Anodised Aluminium	硬化镀锌钢 Hardened, zinc plated steel	UNI EN 12164 CW614N 镀镍黄铜 Brass nickel plated UNI EN 12164 CW614N	AISI 302 不锈钢 Stainless Steel AISI 302	AISI 420 不锈钢 Stainless Steel AISI 420	NBR NBR	硬化镀锌钢 Hardened, zinc plated steel

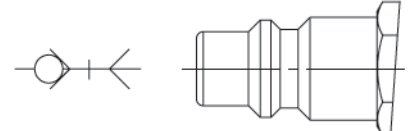

ISO 6150 B-15外形
ISO 6150 B-15 Profile

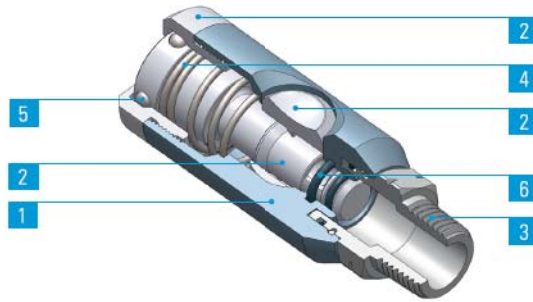

快速接头在安装后依然可以调整方向。
The coupling will remain swivelling after installation.

连接 - 断开

CONNECTION - TO RELEASE

只需将接头插入本体即可。

Insert the plug into the coupling

如需将接头与内螺纹本体断开，必须执行以下2个简单步骤：

To disconnect the plug follow instructions below:

将接头插入内螺纹本体

Plug inserted in the coupling

阶段1：

Step 1:

按下松开按钮，从下游回路排出空气；此阶段内接头的内螺纹内部依然锁定。

Press the button once to vent the downstream air from the circuit; at this time the plug is still captive in the coupling.

阶段2：

Step 2:

再次按下按钮，从内螺纹本体取出接头。

Press the button one more time to release the plug.

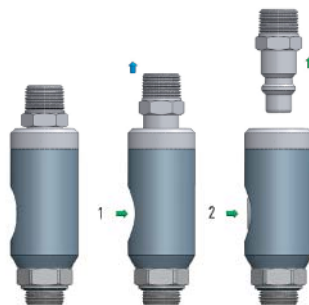

PU 44-11

外螺纹接头体

Male Coupling

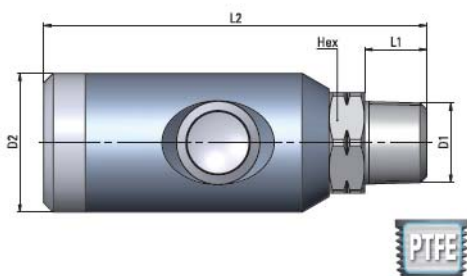

类型	D1 NPTF	D2	L1	L2	HEX (mm)	g	Δ
11 00 38	3/8	29	13	80	21	153.00	
11 00 12	1/2	29	17	84	22	-	

PU 44-12

内螺纹接头体

Female Coupling

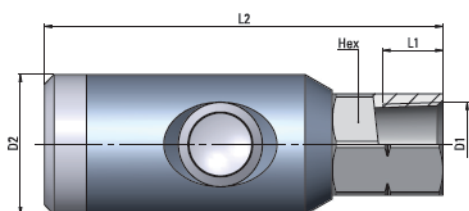

类型	D1 NPTF	D2	L1	L2	HEX (mm)	g	Δ
12 00 38	3/8	29	12.5	82.5	21	168.50	
12 00 12	1/2	29	13.5	84.5	24	-	

PU 44-20

外螺纹插头体

Male Plug

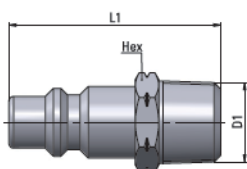

类型	D1 NPTF	L1	HEX (mm)	g	Δ
20 00 38	3/8	45.5	17	-	
20 00 12	1/2	45.5	18	-	

PU 44-21

内螺纹插头体

Female Plug

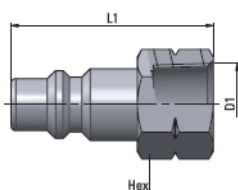

类型	D1 NPTF	L1	HEX (mm)	g	Δ
21 00 38	3/8	42.5	17	-	
21 00 12	1/2	42.5	20	-	

PU 45

安全型按钮式快速接头，ARO 210外形

Push-Button Safety Coupling, according to ARO 210

1	2	3	4	5	6	
本体 Body	按钮、阀芯和排气孔 Button, Valve and Venting Ring	螺纹 Thread	弹簧 Springs	滚珠 Balls	密封圈 Seals	接头 Plugs
阳极氧化铝 Anodised Aluminium	硬化镀锌钢 Hardened, zinc plated steel	UNI EN 12164 CW614N 镀镍 黄铜 Brass nickel plated UNI EN 12164 CW614N	AISI 302 不锈钢 Stainless Steel AISI 302	AISI 420 不锈钢 Stainless Steel AISI 420	NBR NBR	镀镍钢 Nickel plated steel

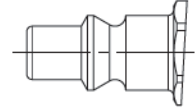
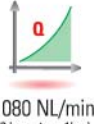

ARO 210型材
ARO 210 Profile

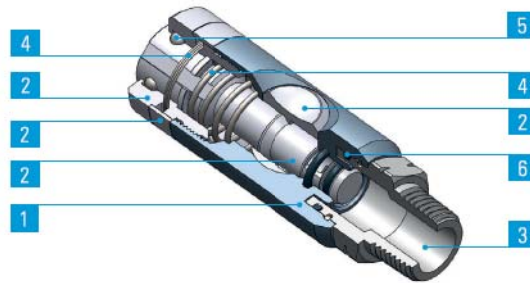

快速接头在安装后依然可以调整方向。
The coupling will remain swivelling after installation.

连接 - 断开

只需将接头插入本体即可。

如需将接头与内螺纹本体断开，必须执行以下2个简单步骤：

将接头插入内螺纹本体

阶段1：

按下松开按钮，从下游回路排出空气；此阶段内接头的内螺纹内部依然锁定。

阶段2：

再次按下按钮，从内螺纹本体内取出接头。

CONNECTION - TO RELEASE

Insert the plug into the Coupling

To disconnect the plug follow instructions below:

Plug inserted in Coupling

Step 1:

Press the button once to vent the downstream air from the circuit; at this time the plug is still captive in the coupling.

Step 2:

Press the button one more time to release the plug.



PU 45-11

外螺纹接头体

Male Coupling

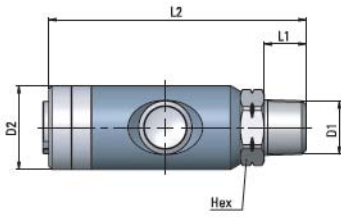

类型	D1 NPTF	D2	L1	L2	Hex	g $\Delta\Delta$
11 00 14	1/4	26	13	82.5	21	-
11 00 38	3/8	26	13	81.5	21	-
11 00 12	1/2	26	17	85.5	22	-

PU 45-12

内螺纹接头体

Female Coupling

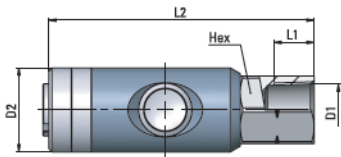

类型	D1 NPTF	D2	L1	L2	CH	g $\Delta\Delta$
12 00 14	1/4	26	9	78.5	21	-
12 00 38	3/8	26	10	80.5	21	-
12 00 12	1/2	26	11	82.5	24	-

PU 45-20

外螺纹插头体

Male Plug

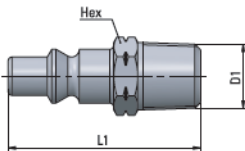

类型	D1 NPTF	L1	CH	g $\Delta\Delta$
20 00 14	1/4	40	14	-
20 00 38	3/8	40	18	-
20 00 12	1/2	45	22	-

PU 45-21

内螺纹插头体

Female Plug

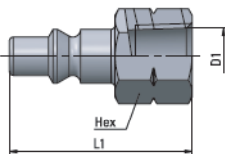

类型	D1 NPTF	L1	CH	g $\Delta\Delta$
21 00 14	1/4	38	17	-
21 00 38	3/8	38	20	-
21 00 12	1/2	42	24	-

GX Safety

cmatic[®]
PNEUMATIC FITTINGS

316L 不锈钢安全快速接头
316L Stainless Steel Safety Couplings



GX 46

安全型按钮式快速接头，欧洲外形

Push-Button Safety Coupling, according to European profile

1	2	3	4	5	6	
本体 Body	按钮、阀芯和排气孔 Button, Valve and Venting Ring	螺纹 Thread	弹簧 Springs	滚珠 Balls	密封圈 Seals	接头 Plugs
AISI 316L 不锈钢(1.4404) Stainless Steel AISI 316L (1.4404)			AISI 302 不锈钢 Stainless Steel AISI 302	AISI 420 不锈钢 Stainless Steel AISI 420	FPM FPM	AISI 316L 不锈钢(1.4404) Stainless Steel AISI 316L (1.4404)

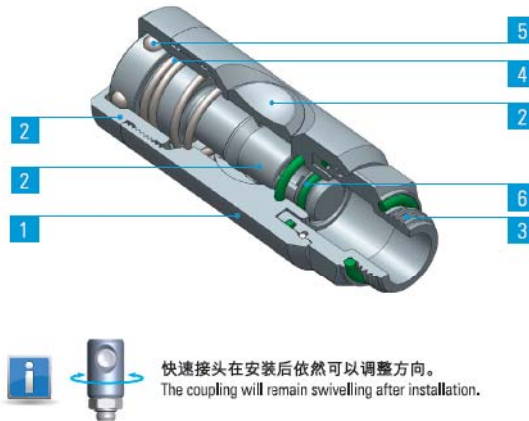
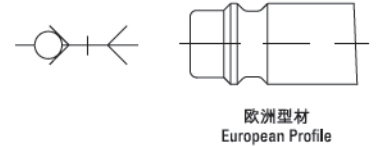

连接 - 断开 CONNECTION - TO RELEASE

只需将接头插入本体即可。

Insert the plug into the Coupling

如需将接头与内螺纹本体断开，必须执行以下2个简单步骤：

To disconnect the plug follow instructions below:

将接头插入内螺纹本体

Plug inserted in Coupling

阶段1：

Step 1:

按下松开按钮，从下游回路排出空气；此阶段内接头的内螺纹内部依然锁定。

Press the button once to vent the downstream air from the circuit; at this time the plug is still captive in the coupling.

阶段2：

Step 2:

再次按下按钮，从内螺纹本体内取出接头。

Press the button one more time to release the plug.

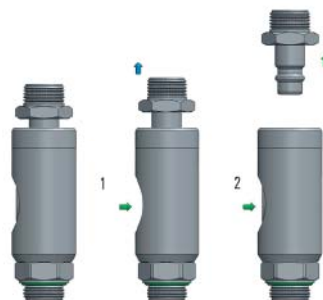

GX 46-10

外螺纹接头体

Male Coupling

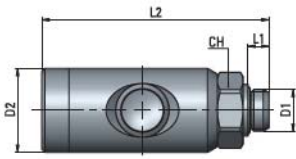

类型	D1	D2	L1	L2	CH	g $\Delta\Delta$
10 00 14	G1/4	26	6.5	70	21	177
10 00 38	G3/8	26	7	70	21	176.5
10 00 12	G1/2	26	8.5	72.5	25	197.5

GX 46-12

内螺纹接头体

Female Coupling

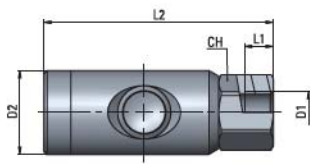

类型	D1	D2	L1	L2	CH	g $\Delta\Delta$
12 00 14	G1/4	26	9	73.5	21	190
12 00 38	G3/8	26	10	75.5	21	190
12 00 12	G1/2	26	11	77.5	24	200.5

GX 46-13

软管用接头体

Coupling with Hose Connection

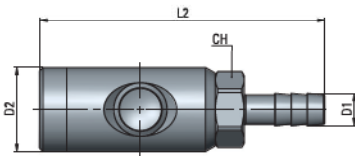

类型	管径 \varnothing_i	D1	D2	L2	CH	g $\Delta\Delta$
13 06 00	6	7	26	88.5	21	178.5
13 09 00	9	10	26	88.5	21	184
13 13 00	13	14	26	88.5	21	188.5

更多插头体信息，请参看GX10相关部分。

For further info on the plugs to use, please revert to the **GX10** section.

